

# ASTRA - ACCELERATOR MODEL 1



Document includes technical information for : **ASTRA** Accelerator model 1  
Trim configuration UL/cUL/FM  
Trim configuration UL/cUL/FM/LPCB

*The ASTRA Accelerator Model-1 is available in **RED** or **BLACK***

**Venus Fire Protection**

4105 Portland blvd. Sherbrooke, Quebec, Canada J1L 1X9

venus-fire.com / sales@venus.ca

t: 1-819-820-8000 / f: 1-819-820-8002

# ASTRA ACCELERATOR

## MODEL 1

### DESCRIPTION AND INSTALLATION

The **ASTRA** Accelerator is an accessory device used on large dry pipe systems to hasten dry valve operation. NFPA Pamphlet 13 requires that each standard dry valve controlling a system with a capacity of more than 500 gallons must be provided with an accelerator.

In a fire condition, the accelerator redirects air pressure from the system piping into the intermediate chamber of the dry pipe valve. This air pressure assists the water pressure to overcome the pressure differential and opens the dry pipe valve.

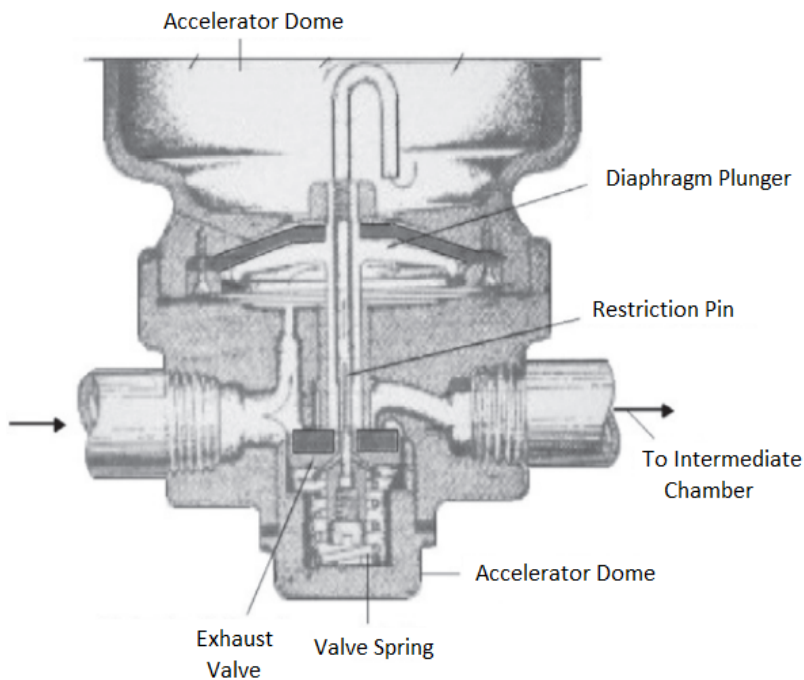

**FIGURE 1**

*Under normal condition, the valve spring keeps the exhaust valve seat up against its seat ring with equal pressure from the piping system above and below the diaphragm.*

*Air pressure from the sprinkler piping can freely pass to the underside of the diaphragm through a hole. Air pressure can seep slowly into the accelerator dome through the restricted orifice formed by the restriction pin and the stem of the dome plunger. With the exhaust valve up against its seat, air pressure cannot pass into the intermediate chamber.*

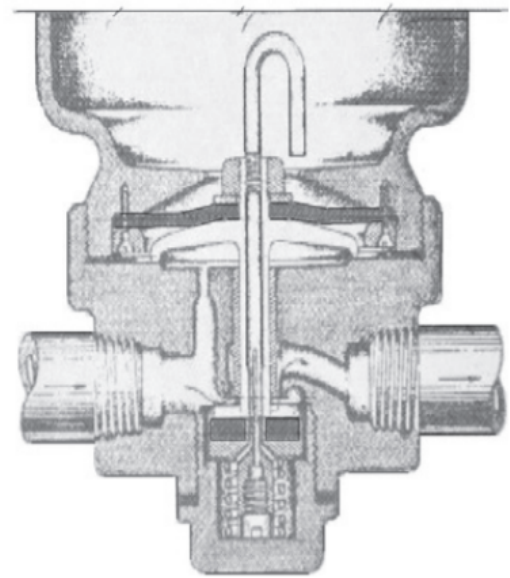

**FIGURE 2**

*Operation of the exhaust valve occurs when an opened sprinkler causes sudden pressure drop in system piping. When a sharp pressure drop occurs, it does not affect the air pressure in the dome immediately. Therefore, the greater pressure in the dome opens the exhaust valve and permits air pressure to pass into the intermediate chamber.*

## OPERATIONAL TESTING OF **ASTRA** ACCELERATOR MODEL-1

Before proceeding with test, make sure that accelerator shut-off valve is open and that the 250 psi air pressure gauges on top of the accelerator dome and in the air supply priming line are equalized at the system air pressure.

1. Close controlling gate valve.
2. Open 2" main drain to relieve pressure under clapper.
3. Close accelerator shut-off valve.

**Note:** *If there are leaks of sufficient magnitude in the joints between the shut-off valve and the accelerator, accelerator operation may occur upon closing the shut-off valve.*

4. Slowly, loosen 1/2" union between the accelerator shut-off valve and the accelerator.
5. Accelerator operation can be detected by the audible tripping of the accelerator followed by decreasing accelerator dome pressure.
6. Retighten 1/2" union between accelerator shut-off valve and accelerator
7. Slowly open accelerator shut-off valve while listening for air discharge through the velocity check. The sound of air escaping through the velocity check will insure that the accelerator has operated.
8. After allowing accelerator dome pressure to drop sufficiently below system air pressure. **fully open accelerator shut-off valve** and allow accelerator dome pressure to equalize.
9. Bring system to proper air pressure.
10. Close 2" main drain.
11. **Open controlling gate valve.**

## RESETTING PROCEDURE

If an Accelerator Model 1 is used with the dry pipe sprinkler system it must be cleaned and reset as follows:

1. Remove bottom plug and attached spring, exhaust valve seat and restriction pin.
2. Carefully clean rubber seat of exhaust valve, exhaust valve seat rings and restriction pin making sure that no foreign matter adheres to them and that they are not damaged. Use smoking pipe cleaner to clean passage in diaphragm plunger and make sure that all water is drained from the accelerator dome. Removal of the accelerator air gauge provides an opening to atmosphere so that the dome can be drained.
3. Replace bottom plug and related parts. If bottom plug gasket is not in good condition, replacement is necessary.
4. Make sure accelerator shut-off valve is open.

After allowing about one-half hour to lapse, check air gauge mounted on accelerator dome to see that accelerator dome pressure has equalized with sprinkler piping pressure.



## ACCELERATOR FIELD REPAIRS

1. Remove accelerator from dry pipe valve after first shutting off the water supply and bleeding the air from the system.
2. Remove bottom plug 85-3 and restriction pin screw 85-9.
3. Remove restriction pin assembly S85-103 being careful not to bend, and exhaust valve assembly S85-102.
4. Remove lower chamber S85-101A from dome 85-19M.
5. Remove retaining ring screws 85-23 and diaphragm retaining ring 85-5M.
6. Remove diaphragm 85-12, diaphragm washer 85-15 and restriction tube 85-11.
7. Clean out all sediment above or below diaphragm.
8. Replace exhaust valve assembly S85-102 with a new one or grind disc smooth with fine grinding compound or emery cloth.
9. If restriction pin assembly S85-103 is bent or rusty, it should be replaced with a new one. The new pin may have to be filed somewhat smaller in some cases or the pressure will not equalize in the dome.
10. If valve spring 85-10 is not in good condition, replace with a new one.
11. Replace diaphragm 85-12, diaphragm washer 85-15 and dome gasket 85-17 with new ones. Gasket 85-17 is important and must be 1/8" thick or it will allow diaphragm plunger 85-4M to protrude too low and keep exhaust valve from closing tight against seat.
12. After desired parts have been replaced, reassemble, being sure everything is air tight. It is easy to have a small leak in some of the gaskets if not extremely careful.
13. Re-install the accelerator on the dry pipe valve and reset the valve in accordance to instructions under Re-setting System on page 3 of this data sheet.

Note: Dome gasket 85-17 is to be coated on both sides with Dow Corning Valve Seal Lubricant, or equivalent, before assembly.

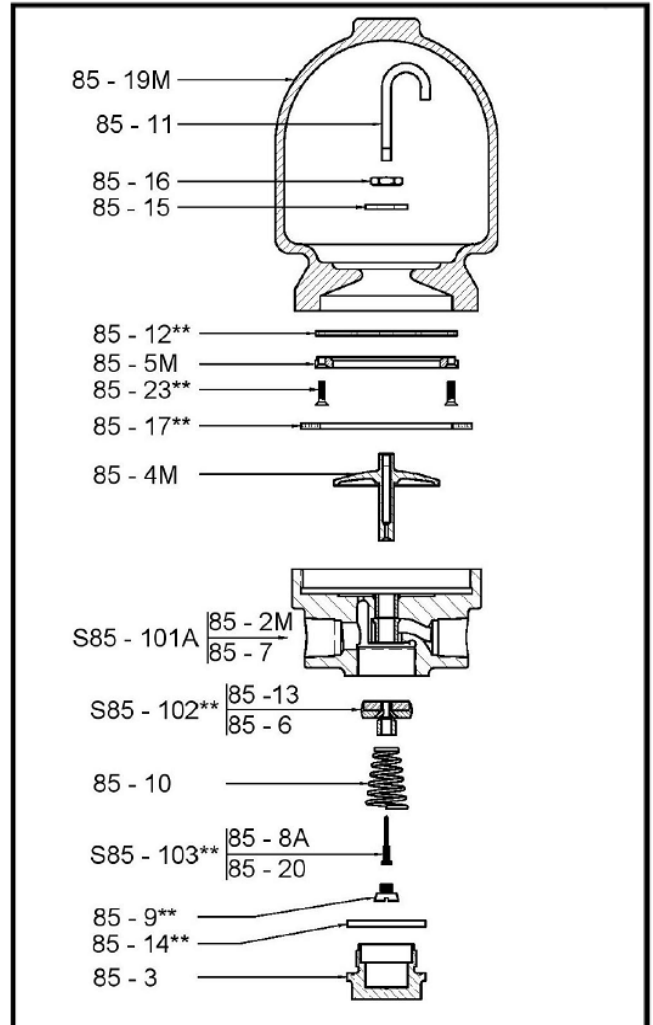

### Accelerator Model 1 – Replacement Parts List Note: Order Replacement Parts by Part number

<u>Part Number</u>	<u>Description</u>	<u>Part Number</u>	<u>Description</u>
85-3	Bottom Plug	85-11	Restriction Tube
85-4M	Diaphragm Plunger	85-12**	Diaphragm
85-5M	Diaphragm Retaining Ring	85-14**	Bottom Plug Gasket
S85-102**	Exhaust Valve assembly	85-15**	Diaphragm Washer
S85-103**	Restriction Pin assembly	85-16	Diaphragm Nut
85-9**	Restriction Pin Screw	85-17**	Dome Gasket
85-10**	Valve Spring	85-23**	Diaphragm Retaining Ring Screw (6)

\*\* Parts included in the Accelerator Repair Kit.



# ASTRA DRY VALVE 3"

## ACCELERATOR TRIM

### MODEL 1 - UL/cUL/FM TRIM CONFIGURATION

NO. ITEM	DESCRIPTION	QTY
1	3" Dry Pipe Valve	1
2	½" x 3" Galv. Nipple	2
3	½" x 6" Galv. Nipple	1
4	½" x 1-½" Galv. Nipple	1
5	½" x 2-½" Galv. Nipple	2
6	½" Galv. Street Elbow	3
7	½" Galv. Elbow	3
8	½" Galv. Union	2
9	½" Brass Check Valve	1
10	½" Brass Ball Valve	1
11	½" Galv. Close	4
12	½" Galv. Tee	1
13	½" Steel Plug	1
14	Accelerator	1
15	Air Gauge	1

ADDITIONAL PARTS TO BE USED WITH 3" DRY VALVE BASIC TRIM	
NO. ITEM	DESCRIPTION
A	Replace ③ In Basic Trim By: ¼" x 5-½" Galv. Nipple
B	Replace ⑦ In Basic Trim By: ¾" Galv. Close - ¾" x ¾" x ½" Galv. Tee - ¾" Galv. Close
C	Replace ⑫ In Basic Trim By: ¾" x 2-½" Galv. Nipple - ¾" x ¾" x ½" Galv. Tee

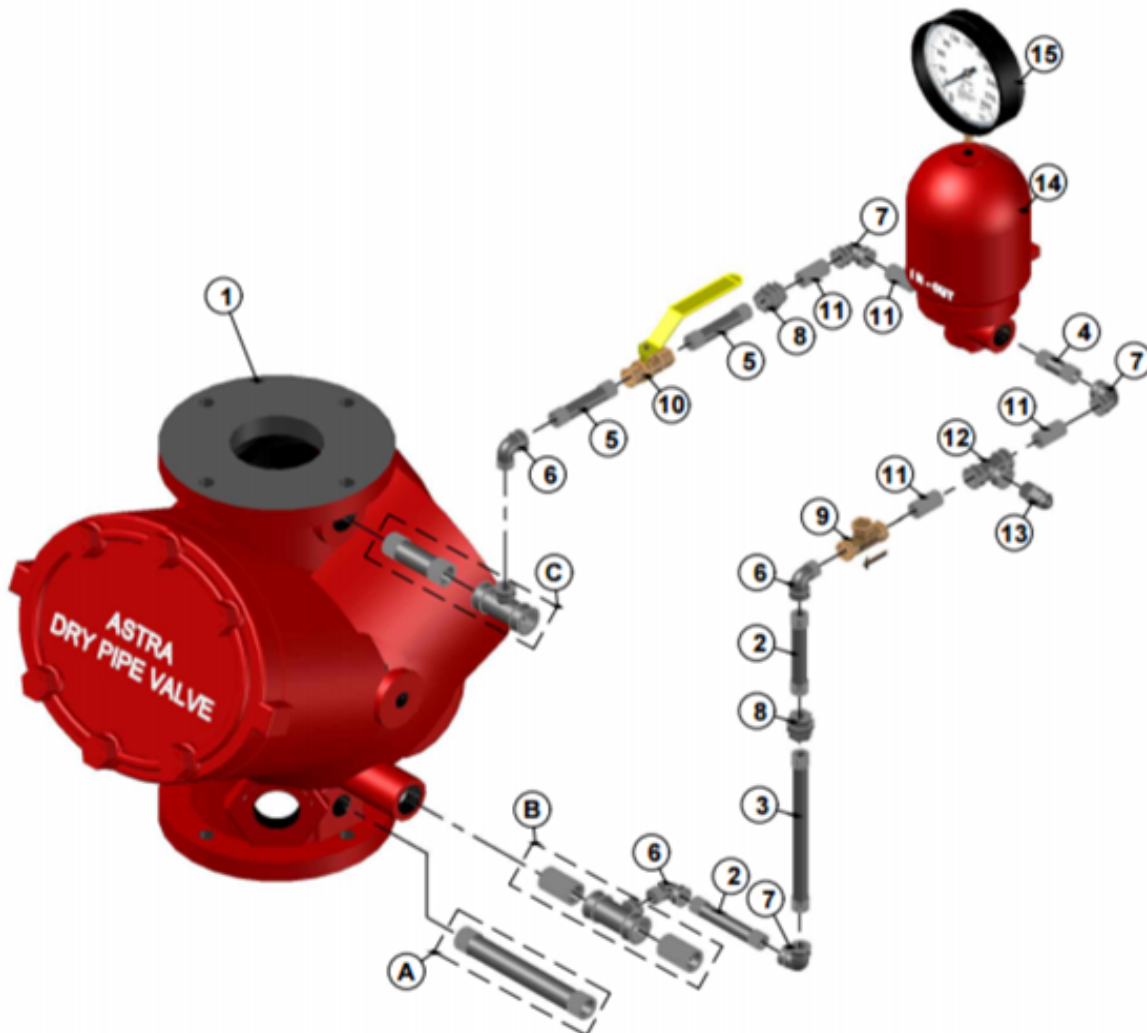

## ASTRA DRY VALVE 4" & 6" ACCELERATOR TRIM

### MODEL 1 - UL/cUL/FM TRIM CONFIGURATION

NO. ITEM	DESCRIPTION	QTY
1	4" Or 6" Dry Pipe Valve	1
2	4" Valve: ½" x 5" Galv. Nipple 6" Valve: ½" Galv. Close	1
3	½" x 6" Galv. Nipple	4
4	4" Valve: ½" x 1-½" Galv. Nipple 6" Valve: ½" x 6" Galv. Nipple	1
5	½" x 1-½" Galv. Nipple	1
6	4" Valve: ½" x 2" Galv. Nipple 6" Valve: ½" x 1-½" Galv. Nipple	1
7	½" Galv. Elbow	4
8	½" Galv. Coupling	2
9	½" Galv. Close	6
10	½" Brass Check Valve	1
11	½" Brass Ball Valve	1
12	½" Galv. Tee	2
13	½" Steel Plug	2
14	½" Galv. Union	2
15	Accelerator Model 1 Astra	1
16	Air Gauge	1
17	¼" x ½" Galv. Bushing	1

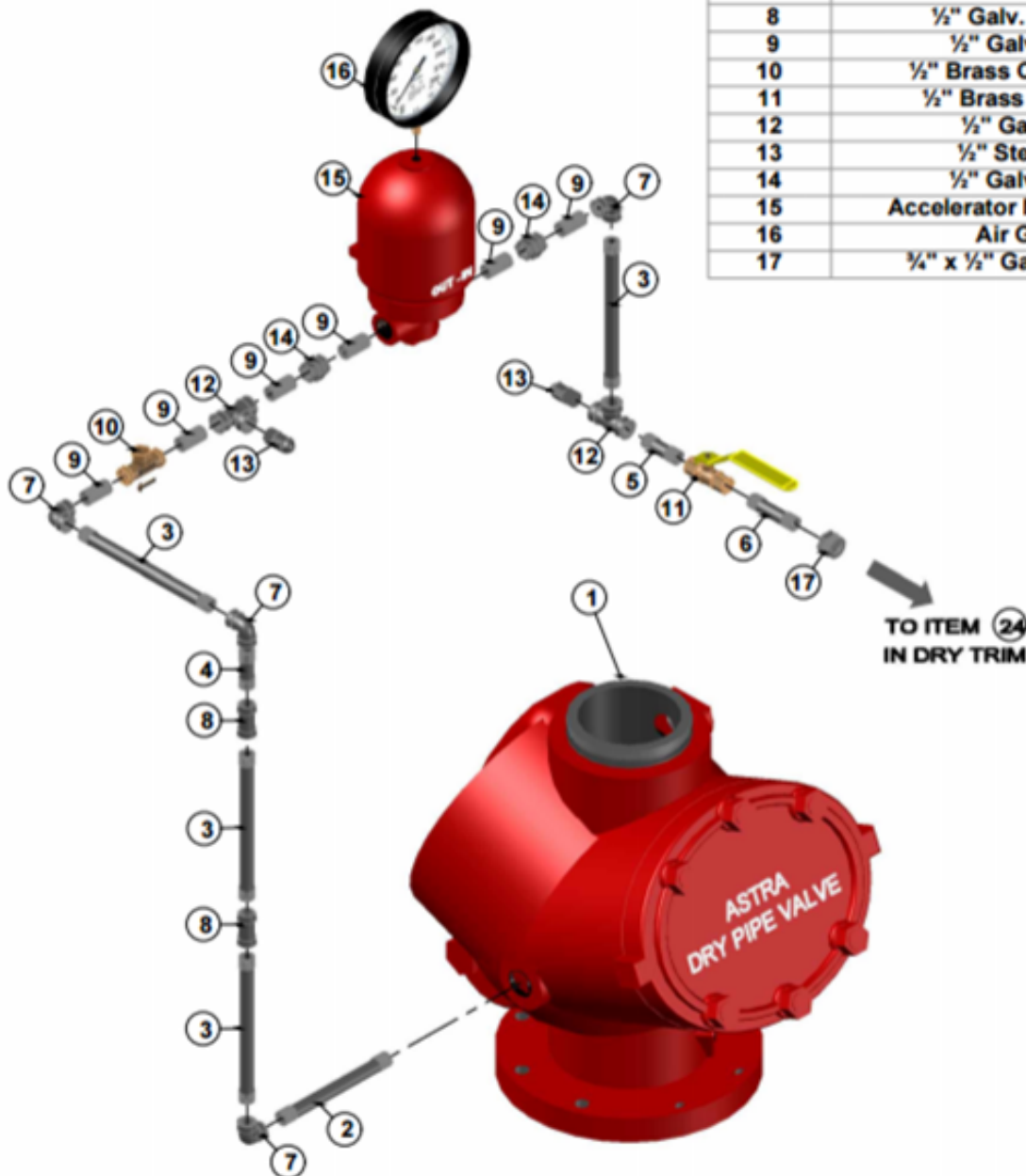

## ASTRA DRY VALVE 3" ACCELERATOR TRIM MODEL 1 - *LPCB TRIM* CONFIGURATION

NO. ITEM	DESCRIPTION	QTY
1	3" Dry Pipe Valve	1
2	½" x 3" Galv. Nipple	1
3	½" x 6" Galv. Nipple	1
4	½" x 4" Galv. Nipple	2
5	½" x 2-½" Galv. Nipple	3
6	½" x 2" Galv. Nipple	1
7	½" Galv. Street Elbow	4
8	½" Galv. Elbow	3
9	½" Galv. Union	2
10	½" Brass Check Valve	1
11	½" Brass Ball Valve	1
12	½" Galv. Close	3
13	½" Galv. Tee	1
14	½" Steel Plug	1
15	Accelerator Model 1 Astra	1
16	Air Gauge	1
17	½" Brass Accelerator Strainer	1
18	¾" x ½" Galv. Bushing	1

TO BE USED WITH 3" DRY VALVE BASIC TRIM LPCB	
PART	DESCRIPTION
A	TO ITEM (25) IN 3" DRY TRIM LPCB
B	TO ITEM (24) IN 3" DRY TRIM LPCB

